

# YHZS35 portable concrete plant

Description of 35m<sup>3</sup>/h portable concrete plant



YHZS35 portable concrete plant is a new type ready mix concrete plant, which put dosing, weighing, conveying, mixing, discharging and electric control system in one movable trailing unit. It is all the same as stationary batching plant to operate and maintain, at the same time, it can be overall mobile

YHZS35 portable concrete plant pulling structure with running system and standard coupling pin included. It can be dragged by trailer. Without foundation and commissioning enables convenient transportation, the mixing plant can be divided into several standard modules, and then be packed into containers.

*Haomei portable concrete plant was especially designed to the users who have a short period construction engineering. It is the ideal equipment for projects that require frequent movement from one construction site to another, such as building, highway, bridge and other construction projects. Contact us for more information!*



### Main Technical Parameter of YHZS35 portable concrete plant

- 1 Capacity: 35m<sup>3</sup>/h(under standard working condition)
- 2 Total power consumption: 62 KW
- 3 Aggregate weighing precision:  $\pm 2\%$
- 4 Cement weighing precision:  $\pm 1\%$
- 5 Water weighing precision:  $\pm 1\%$
- 6 Additive weighing precision:  $\pm 1\%$
- 7 Cycling time: 72 seconds
- 8 Control mode: PLC, can operate on full auto, semi-auto and manual modes
- 9 Mixed material discharge height: 2600mm
- 10 Overall dimension: 13m x 2.2m x 5.5m
- 11 total weight: approximated: 20tons

## Installation of YHZ35 portable concrete plant



## Features of YHZ35 portable concrete plant

Stability from national standard structural steel. | Efficiency from twin shaft mixer and short cycle time. | Reliability from famous brand components. | Quality from accurate weighing. | Mobility from movable trailing unit. | Easy to installation-uninstallation and operating. | Quick to produce from our own specially trained engineers. | Easy to move from compact structure. | Easy to maintain from the best service and parts support. | Easy to clean from mixer with high-pressure automatic cleaning system. | Less foundation costs (80% less than stationary concrete batching plants). | Less maintenance and operating costs. | Less transportation costs. | Minimized concrete transportation costs. | Fast return on investment.

## General layout of YHZ35 portable concrete plant



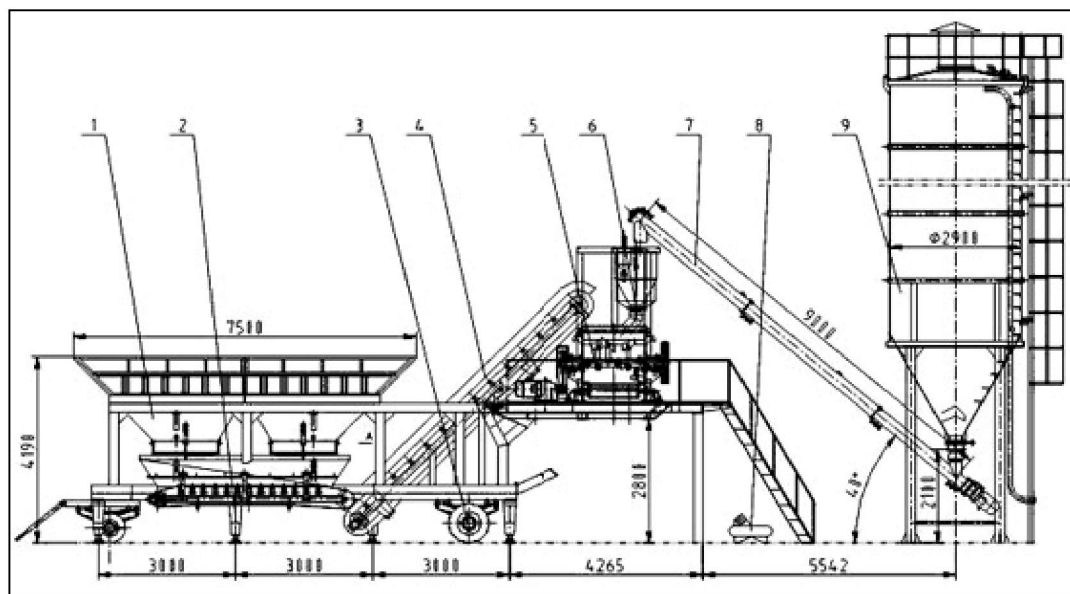
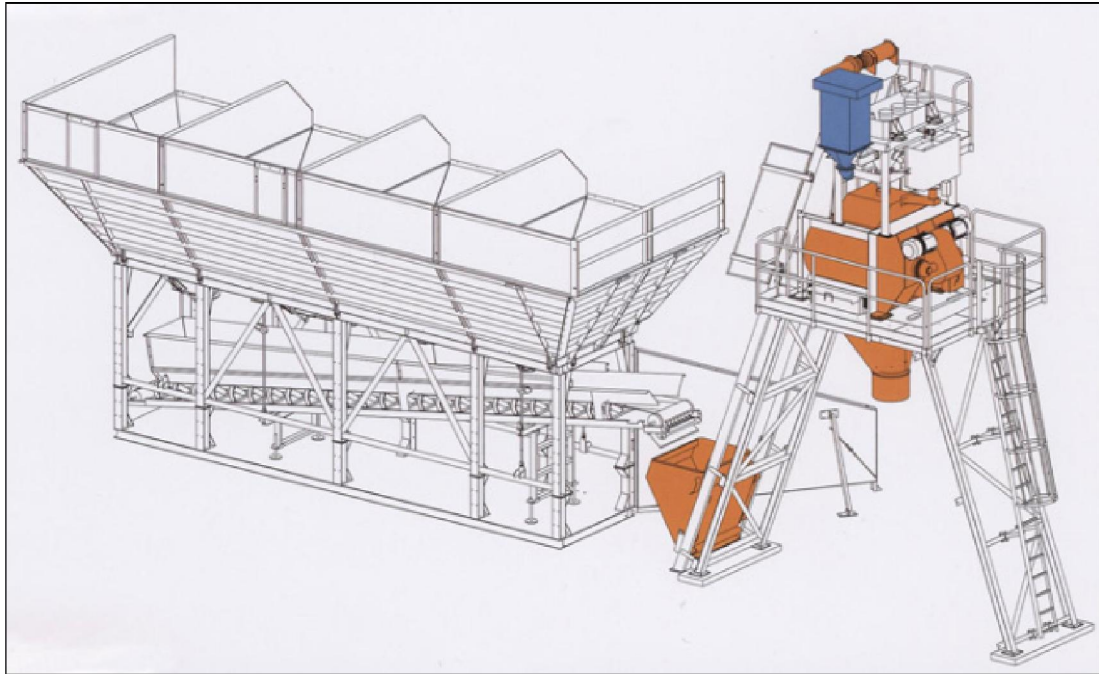

35m<sup>3</sup>/h Portable concrete plant parts

Please note of YHZS35 portable concrete plant

1. The total power doesn't include the power of cement screw;

2. Non-standard design could be made according to clients' demand;

3. The above-mentioned data could be changed due to the designing improvement, please check the updated configuration when purchasing.

### Application of YHZS35 portable concrete plant

It is can applied to various construction sites like road surface, bridges, dams and airport, and also like architectural workings, concrete product plant and commercial concrete production.

### 35m<sup>3</sup>/h Portable concrete plant parts

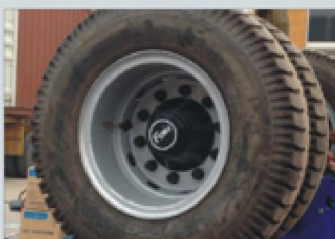

## 35m<sup>3</sup>/h Portable concrete plant basic performance parameters

### Configuration Table

#### YHZD-35 CONCRETE BATCH STATION

No	Description		Specification
1	Batching system	Aggregate hoppers	6m <sup>3</sup>
		Sand hopper with a vibrator	
		Mesh cover	100 × 100
		Air cylinder	QGB80 × 250
		Weighing hopper	2m <sup>3</sup>
		Belt	B650 × 10 × 8400
		Electric drum	YD40106532
		Weighing sensors	CBLGM-S/1000
		Clean device	
2	Aggregate lifting belt conveyor	Trough belt	B650 × 120 × 13400
		Electric drum	YD551256540
		Clean device	
3	Cement weighing system	weighing hopper	0.4m <sup>3</sup>
		motor	7.5Kw
		Weighing sensor	CBLGM-S/200
		Butterfly valve	V1FS300SN
		Canvas cover	200 × 600
		Canvas cover	310 × 300
4	Water weighing system	Water weighing bin	0.3m <sup>3</sup>
		Pneumatic valve	65JDB35-8-0.75 Kw
		Immersible pump	1.1Kw
		Weighing sensor	CBLGM-S/500
5	Additive weighing system	Additive weighing bin	0.05m <sup>3</sup>
		Butterfly valve	65
		Anti-corrosion pump	25CQ-15(0.75Kw)
		Weighing sensor	CBLGM-S/200

		Additive Storage bin	1m3
6	Mixing system	Mixer	JD750 compulsory mixer
		Motor	Y180L-4 30Kw
		Gearbox	XWD8-17
		Air cylinder	QGB-ZZ125 × 150-L3
		Oil lubricator	SNB10-6J
7	Chassis	Main frame	
		Front chassis	900-20
		Rear chassis	825-12
8	Air system supply	Air compressor	5.5Kw
		Electric solenoid	Q25DC-L15
		Air regulation/lubricator/filter combine	QFLJM-L15
		Connector	
		Muffler	L15
		Air tubes	10 × 12mm
9	Control system	Industrial computer	Advantech
		PLC controller	Omron
		Console	
		Electric bin	
		Electric elements	Siemens/ LG
		Air conditioned control room	1P
		Cables	
10	Spare parts and tools with equipment	Relay	DC24V
		Relay	AC220V
		Monkey wrench	12”
		pliers	
		Screwdriver	8”
		Socket spanner and open end spanner	8
		Grease lubricator	
		Hammer	2Pound
		Oil lubricator	
		Oil sealing	For mixer axial end
		Oil sealing	For mixer axial end
		Mixer paddle	For mixer
		Scale board	For mixer

## Installation of YZS25 portable concrete plant



## Installation Preparations what portable concrete plant

concrete batching Plant installation is the greatest guarantee the safe use later, so preparatory work prior to installation we also need to do the full job, then how will the concrete mixing station installation to maximize the potential, we must do the rational and bar below haomei to resolve concrete mixing station preparations have?

- 1, the first given by the manufacturer in accordance with the concrete batching Plant installation foundation plans, and prepare the ground and embedded. Installed base must be solid, consistent architectural design specifications.



- 2, good planning construction of access roads, temporary schwing concrete placing booms bridge, wharf and stockpiling area, and undertake leveling, not only did water, electricity, land leveling.
- 3, assembly concrete batching Plants hoisting equipment, such as cranes, tower vehicles, the installation process is not only to choose the right position, the more important is that we must use professional operators to install.
- 4, concrete batching Plantis mainly responsible positions in their own due diligence to ensure that every job acceptance, the only way to ensure safe and efficient work. Security is no small matter concrete mixing station, so we must not relax, only to lay a good foundation for a solid backing, so in order to produce efficiently must be taken seriously for each job.



To install a concrete batching plant correctly is very important to productivity of concrete batching plant. Here are some installation steps to install a concrete batching plant

## Installation steps of concrete batching plant

- (1) Installation of finished material adhesive tape conveyor Expand finished material adhesive tape conveyor at its bends and then put frame on the base. Next, link legs with conveyor as well as the bracing piece and lifting lug. Thirdly, lift the front of conveyor and like legs and bracing piece well. Finally, fasten anchor bolt of legs well.
- (2) Installation of host and powder batching system Sling the rack of host and put it on the base. Then fasten its anchor bolt.

- (3) Installation of storage bin Sling storage bin and rise up legs. Link walking board, ladder and storage bin well.
- (4) Installation of aggregate dosing machine sling aggregate dosing machine to put it on the base. Link blank as well as heightening plate and blank. Next, expand aggregate conveyor. Link rack to make motorized pulley align cover hole center of concrete mixer. Finally, fasten anchor bolt.
- (5) Installation of cement silo Assemble all parts of cement silo well on the ground and then lift cement silo. Make support of it orient to power batching system and then fasten it. In the end, fasten anchor bolt.
- (6) Installation of screw conveyor Sling screw conveyor. Link spherical hinge of screw conveyor and discharging outlet of cement silo well to make discharging outlet align feeding inlet. Then link conveyor and lifting lug of cement silo by steel wire rope. Finally, fasten anchor bolt.
- (7) Lift water pump to a proper position and link output pipe well.
- (8) Put air compressor at one side of storage bin. Link exit of air compressor with entrance of gas control box. Lead exit of gas control box to air tube of cement silo.



## After completion of the concrete batching plant produce what issues need attention

concrete batching plant will be some unforeseen problems in production, it requires staff each position must be serious and responsible, to ensure that the production of some minor problems can be solved in time, but after the completion of production requires concrete batching station clean-up work, so as to ensure the efficient production next. So today we take a look at the concrete batching plant After

production problems which need attention.

- 1, frozen season, was completed pump should be exhausted, additional coolant pump, water tank, additional agent tank, water, additives in the pipeline residual water, additives to prevent damage to Diesel concrete pump the pump and tubing, and start the pump additional coolant pump operate for 1-2 minutes.
- 2, clean the batching tank inside and outside wall fouling, the discharge mouth, concrete residue agitator shaft and discharge door, where rinse with water, if necessary, add a small amount of stone and water, stirring for several minutes release. Water for washing cars, and for the additional agent tank system.
- 3, the lubrication points are located out door shaft mixer, each hopper and weighing Doumen shaft, tape transport, machine roller, roller, roller bearings, drive chains, screw shaft, the lower bearing and host large gear, etc.
- 4, adjusted when checking blades, scraper, stirring arms and other necessary clearance for wear or replaced; vibrators without loosening bolts; check the electrical contact device; static and dynamic contact relay damage and burnout. These are concrete batching plant production work after the completion of the inspection and maintenance issues, although more complicated, but we must make these basic smooth production work can only be assured of.

packing & shipping

## concrete batching Plant

### Packaging Details:

the host machine and other steel frame structure packed nakedly in the container; the electric items and installation components packed with strong and standard wooden packages. A wooden-box with the size of 60cm\*60cm\*60cm will be used for small items like bolt, nut, screw etc.

- 1. Container guarantee to not be damaged at the shipping.
- 2. Protective Packaging
- 3. Protective packaging according to the characteristics of the products. Packages after the water spray test, no water leakage.
- 4. Proof packaging Take the necessary measures moisture proof packaging goods.
- 5. Rust-proof packaging Products sealed with rust-proof material has a very good rust resistance, easy to remove











**shipping:**

by sea or by train; we have rich experience of shipping by sea or by train;



<http://haomei.biz/products/mobile-concrete-mixing-plants/250-mobile-concrete-mixing-plants.htm>  
1

About Haomei

Haomei machinery equipment co., Ltd is located in the famous machinery capital of Zhengzhou, China. We are professional machinery products manufacturer- featuring a wide range of quality mobile concrete mixer, concrete batching plant, mobile concrete plant, concrete pump, truck pump with boom, truck mixer, etc. We adhere to the policy of "QUALITY FIRST AND INTEGRITY WINS" to cooperate with clients from all over the world. Seeking for long-term relationship and mutual benefit is our unstoppable goal.

# Our Factory



Our company covers over 100 acres with workshop area of more than 50,000 square meters has 5 branches. We have over 1000 technical workers and 80 engineers equipped with advanced producing and inspecting machines with strict management. We focus greatly on our products quality and with such quality our products have been receiving admiration by clients from over 30 provinces in China and royal clients from overseas..

We categorize files for clients by computer so that we can view clients feedback and comments in time, tracking services and long-term





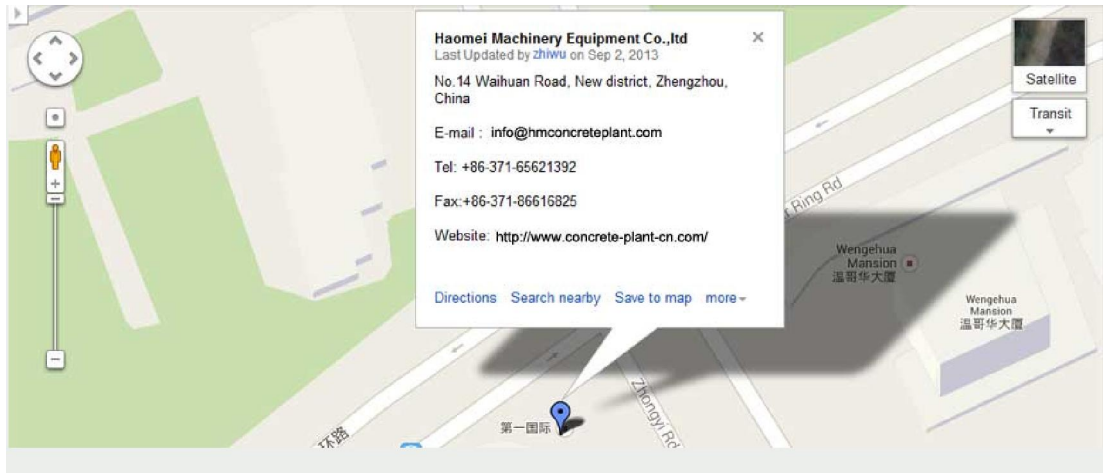

Haomei Machinery Equipment Co.,Ltd

Add : No.14 Shangwu Outer Ring Rd, New District, Zhengzhou, China.

E-mail [info@hmconcreteplant.com](mailto:info@hmconcreteplant.com)

Tel: +86-371-65621392

Fax: +86-371-86616825

Website: <http://www.mobile-concrete-batching-plant.com/>